

FAMILIA 11D
FAMILY

V. BOLA "BASIC" BIDIRECCIONAL
BIDIRECTIONAL "BASIC" BALL VALVE

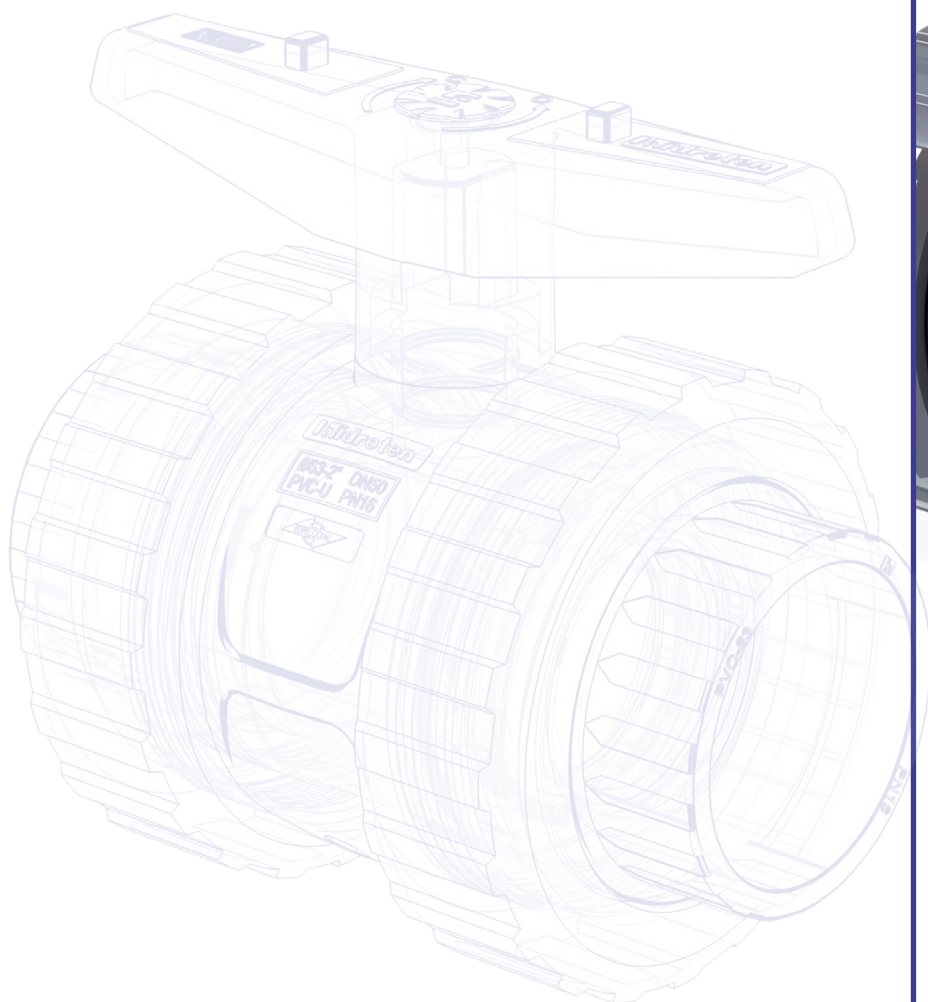



Válvula bidireccional

La gama de válvulas de bola bidireccionales se distinguen por su portateflón roscado, que permite su instalación en cualquier dirección y además proporciona un par de maniobra uniforme. Esto la convierte en una válvula perfecta para aplicaciones industriales al evitar descargas accidentales por instalación incorrecta.

The range of bidirectional ball valves are distinguishable by their threaded teflon adaptor which allows its installation in any direction and provides a uniform operation torque. It turns into the perfect valve for industrial applications as it avoids accidental discharges due to a wrong installation.



Maneta de doble uso

La maneta de las válvulas bidireccionales no sólo sirven para abrir y cerrar la válvula, sino que se puede utilizar a modo de llave para el ajuste del apriete del portateflón, pudiendo ajustar de este modo el par de maniobra de la misma.

The handle of bidirectional valves is not only used to close or open the valve, but they are also used as a wrench to adjust the teflon adaptor and thus it can adjust the torque.



Perfecta para la motorización

El portateflón roscado ofrece una gran ventaja a la hora de automatizar las instalaciones, ya que se independiza el par de maniobra de la válvula del apriete de las tuercas, teniendo un funcionamiento totalmente estable y alargando la vida de los actuadores que no sufrirán por el aumento de par de la válvula.

The threaded teflon adaptor offers a great advantage when automating installations because the torque of the valve separates from the nut torque and it works in a stable way extending the lifespan of the actuators which will not be affected by the increase of the valve torque.



CERTIFICACIONES / CERTIFICATIONS

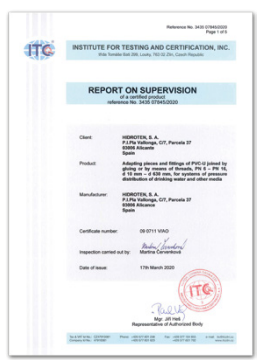

En tuberías según norma UNE-EN 1452 (PVC-U) y UNE-EN 12201 (PE).

Inside the pipes according to the standard UNE-EN 1452 (PVC-U) and UNE-EN 12201 (PE).



SECTOR	Industria, piscina y agricultura / <i>Industry, swimming pool and agriculture</i>
MATERIAL	PVC-U / <i>PVC-U</i>
CIERRE BOLA / BALL CLOSING	PTFE
JUNTAS TÓRICAS / O-RING	EPDM opción VITON (identificado mediante tapón negro) / <i>EPDM option VITON (identified with black cap)</i>
MANETA / HANDLE	Maneta ergonómica, sobredimensionada y con función de llave de apriete del portateflón / <i>Ergonomic and oversized handle with seal carrier tighten function</i>
MOTORIZACIÓN / ACTUATION	Motorización mediante abrazadera desde Ø20 hasta Ø50 y mediante torreta para Ø63, 75 y 90 / <i>Actuation by clamp in from Ø20 to 50 and by actuator support in Ø63, 75 and 90</i>
PN	PN 16 desde Ø20 a 63 / <i>PN 16 from Ø20 to 63</i> PN 10 desde Ø75 a 90 / <i>PN 10 from Ø75 to 90</i>
MEDIDAS / MEASURES	Desde Ø20 a 90, 1/2" - 3" / <i>From Ø20 to 90, 1/2"-3"</i>

DESPIECE / QUARTERING

1. Manguito salida encolar PVC-U
2. Maneta bidireccional
3. Sistema de apriete integrado
4. Bola PVC-U
5. Tapón EVA
6. Tornillo fijación INOX A-4
7. Juntas tóricas EPDM / VITON
8. Vástago PVC-U
9. Junta cierre bola PTFE
10. Portateflón roscado PVC-U
11. Junta cierre EPDM
12. Junta cierre portateflón EPDM
13. Cuerpo PVC-U
14. Junta cierre manguito EPDM

1. PVC-U solvent socket outlet sleeve
2. Bidirectional handle
3. Integrated fastening system
4. PVC-U ball
5. EVA top plug
6. EPDM / VITON o-rings
7. Stainless steel attachment screw A-4
8. PVC-U piston rod
9. PTFE ball seal
10. PVC-U threaded port teflon
11. EPDM seal
12. EPDM rubber sealing ring
13. PVC-U body
14. EPDM sleeve seal

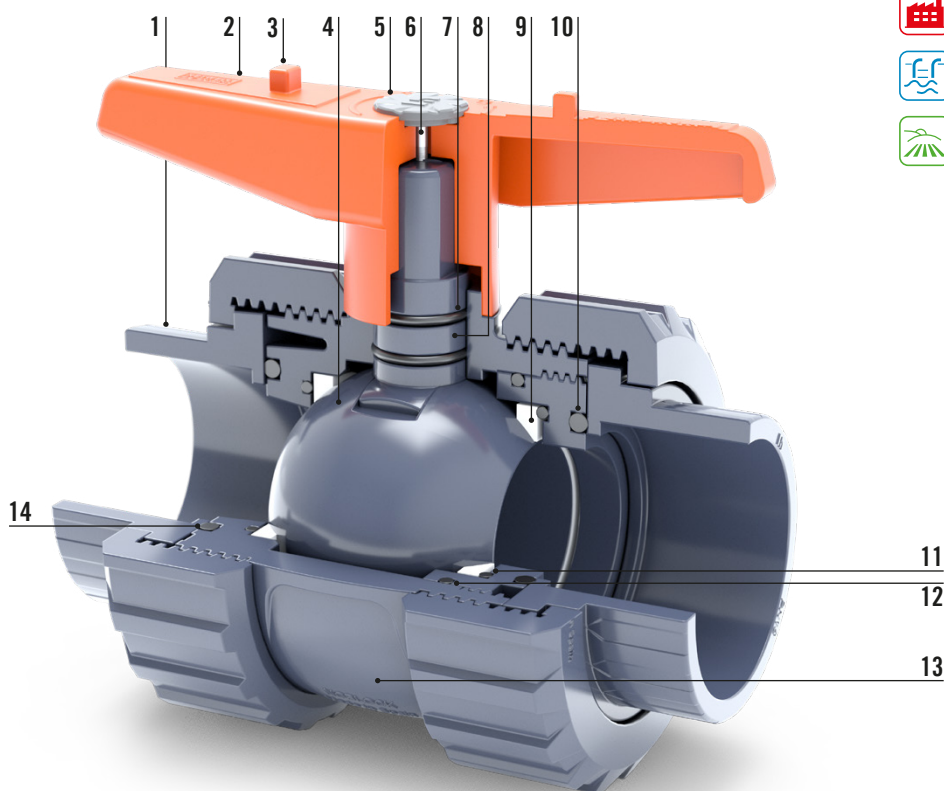

CURVAS PÉRDIDAS DE CARGA / LOAD LOSS CURVES

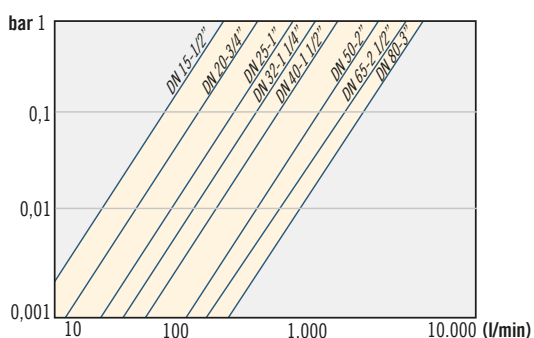

PARES DE MANIOBRA / OPERATION TORQUE

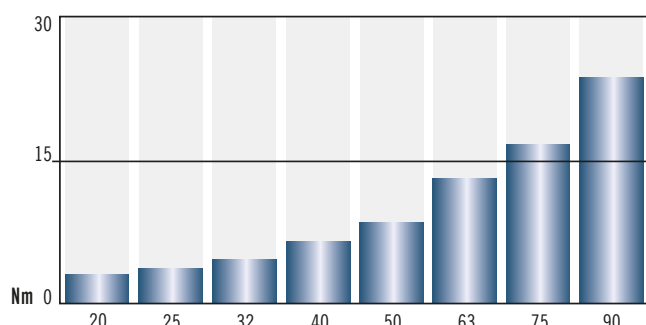

CARACTERÍSTICAS ACTUADOR ELÉCTRICO / ELECTRIC ACTUATORS CHARACTERISTICS

Especificaciones / Specifications	L10	H10	B20	S20	B35	S35	B55	S55
Voltaje (V) / Voltage (V)	24 VAC/VDC	110-220 VAC/VDC	12 VAC/VDC	24-240 VAC 24-135 VDC	24 VAC/VDC	24-240 VAC 24-135 VDC	24 VAC/VDC	24-240 VAC 24-135 VDC
Frecuencia (Hz) / Frecuence (Hz)	50/60	50/60	50/60	50/60	50/60	50/60	50/60	50/60
Tiempo maniobra en vacío (s) / Operation time unload	17	17	9 sec/90°	9 sec/90°	9 sec/90°	9 sec/90°	13	13
Par maniobra (Nm) / Maneuver coupling	10	10	20	20	35	35	55	55
Par arranque (Nm) / Starting coupling	12	12	25	25	38	38	60	60
Tiempo bajo tensión (%) / Time under pressure	75	75	75	75	75	75	75	75
Protección IEC 60529 / Protection IEC 60529	IP-65	IP-65	IP-67	IP-67	IP-67	IP-67	IP-67	IP-67
Ángulo maniobra (°) / Maneuver angle	90°-180°- 270°	0°-90°-180°	0° -90°					
Temperatura (°C) / Temperature	-20°C +70°C							
Interruptor final carrera / Switch box assy	4 SPDT micro		4 SPST NO micro (2 finales de carrera y 2 confirmaciones)					
Resistencia calefactora (W) / Heater resistance	3,55		3,5					
Conectores / Connectors	DIN 43650 ISO 4400 & C 192		Conector pequeño DIN 43650/C. Conector grande EN 175301-803 FORM A					
Conexión ISO 5211 / Connection ISO 5211	F03 - F05		F03-F04-F05		F03-F04-F05		F05-F07	
Conexión DIN 3337 - Doble cuadrado estándar/opcional Connection DIN 3337 - Standard double frame/optional	14 / 9 o 11		14 / 9 o 11		14 / 9 o 11		17 / 11 o 14	
Peso (kg) / Weight	0,9	0,9	1,8	1,8	1,9	1,9	2,4	2,4

- Actuadores eléctricos multivoltaje rotativos de 1/4" de vuelta.
- Control electrónico del par para obtener un funcionamiento suave y suspendiendo la alimentación en caso de ser sobrepasado el par máximo (obstrucciones), protegiendo el mecanismo del actuador.
- Control visual de operación mediante un led externo indicador del estado del actuador.
- Mando manual de emergencia, seleccionando el funcionamiento manual, se aísla el motor de los engranajes y se puede accionar manualmente la válvula.
- Control automático de la temperatura, gracias a un calefactor interno para mantener la temperatura interior entre 20 y 30°C y evitar así daños por condensación.
- Materiales anticorrosivos para un funcionamiento óptimo en cualquier ambiente.
- Opción de posicionador digital DPS 2005 para señales de control 4-20 mA 0-10V.
- Opción cierre de seguridad mediante baterías, sistema BSR.

- Electric multi-voltage actuator, rotation of 1/4" revolution.
- Electronic control of the coupling in order to ensure a smooth functioning and to suspend alimentation if it exceeds the maximal coupling (obstructions), which protects the actuator mechanism.
- Visual control of the operation by means of an external LED showing the actuator state.
- Emergency manual command, by selecting the manual use, the engine gets isolated from the gear assembly and it is possible to act the valve manually.
- Automatic temperature control, by means of an inner heater to maintain the internal temperature between 20 and 30°C, avoiding damages that could be caused by condensation.
- Anticorrosive materials for an optimal functional in any environment.
- Option of digital positioner DPS 2005 for control signals 4-20mA 0-10V.
- Option of security closing using batteries, BSR system.

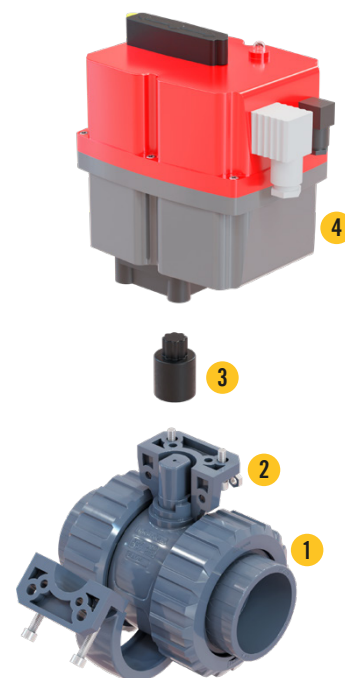

Motorización sistema Bidireccional.
Actuation Bidirectional System.

N.	SECUENCIA / SEQUENCE
1	Válv. bidireccional / Bidirectional valve
2	Abrazadera soporte / Clamp support
3	Adaptador / Adapter
4	Actuador / Actuator

CARACTERÍSTICAS ACTUADOR NEUMÁTICO / PNEUMATIC ACTUATORS CHARACTERISTICS

■ Los actuadores de Simple efecto, son aquellos que realizan la apertura mediante aire y el cierre mediante unos muelles de seguridad.

■ Single acting ensures the opening by means of air and the closing by means of security springs.

MODELO MODEL	CONSUMO CONSUMPTION (Lt/ciclo)	PAR MUELLES (Nm) SPRING TORQUE		PAR ALIMENTADOR (Nm) FEEDER TORQUE		PESO (kg) WEIGHT	Presión aire 6 bar tiempo maniobra (sec.) / Air pressure 6 bar maneuver time	
		0°	90°	0°	90°		APERTURA OPENING	CIERRE CLOSING
H050 SE	0,23	11,5	7,0	11,5	7,0	1,2	0,6	0,6
H063 SE	0,45	18,5	12,5	18,5	12,5	1,8	0,7	0,9
H075 SE	0,61	45,1	25,3	45,2	25,3	3,3	0,6	1
H100 SE	1,8	106,4	60,0	106,4	60,2	6,8	1,1	1,3

■ Los actuadores de Doble efecto, son aquellos que tanto para el movimiento de apertura como para el de cierre lo realizan mediante aire.

■ Double acting ensures both opening and closing movement using air.

MODELO MODEL	CONSUMO CONSUMPTION (Lt/ciclo)	PAR ACTUADOR MODEL	PESO ACTUADOR (kg) ACTUATOR WEIGHT	Presión aire 6 bar tiempo maniobra (sec.) / Air pressure 6 bar maneuver time	
				APERTURA OPENING	CIERRE CLOSING
H050 DE	0,23	18,5 Nm	1,07	0,6	0,6
H075 DE	0,61	70,2 Nm	2,90	0,6	0,7

■ Acabado de la superficie inferior del cuerpo (Ra 0,4-0.6 um) para reducir al mín. la fricción y maximizar la vida del actuador. Protección externa cuerpo: anodizado duro. 500 Hrs. Cámara Niebla salina según ASTM B117-73. Protección externa tapas: recubrimiento epoxy-poliéster.

■ Patines deslizantes, material de bajo cociente de fricción (LAT LUB) evitando contacto metal-metal, fácilmente reemplazable, para su mantenimiento con doble taladro inferior para el anclaje y centrado de la válvula según norma ISO 5211 y DIN 3337.

■ Conexión inferior eje cuadrado hembra según ISO 5211/DIN 3337 para el montaje a 45° o 90° indistintamente.

■ Montaje directo electroválvula NORMA NAMUR. / Montaje accesorios según norma NAMUR VDI/DE 3845.

■ Temperatura de trabajo -20°C a +80°C.

■ Limitador de carrera a la apertura y al cierre; control de funcionamiento y estanqueidad 100% a través del sistema electrónico. Certificación individual.

■ Finish of the body lower surface (Ra 0.4-0.6 um) to reduce at min. the friction and maximize the actuator life. Body external protection: strong anodized 500Hrs. Salt fog chamber according to ASTM B117 -73. Lid external protection: epoxy-polyester coating.

■ Slipping skates, low friction quotient material (LAT LUB) avoiding metal-metal contact, easily replaceable, for its maintenance with lower double hole for anchoring and centering of the valve according to ISO 5211 and DIN 3337 standards.

■ Lower connection with female square shape axis according to ISO 5211/DIN 3337 for 45° or 90° assembly, without distinction.

■ Direct assembly of electrovalve NAMUR STANDARD / Fitting assembly according to NAMUR VDI/DE 3845.

■ Working temperature from -20°C to +80°C.

■ Motion limiter for opening and closing; Control of functioning and impermeability 100% through the electronic system. Individual certification.

AJUSTE PORTATEFLÓN / ADJUSTMENT PORT-TEFLON



1. Liberar el cuerpo de la válvula, aflojando las tuercas en el sentido de las flechas. / Release the valve body untightening the nuts as shown in the picture.



2. Manteniendo la válvula en posición cerrada sacamos la maneta, que acoplamos al portateflón, sirviendo de herramienta. / With closed valve, release the handle, and use it as wrench in the closing carrier.

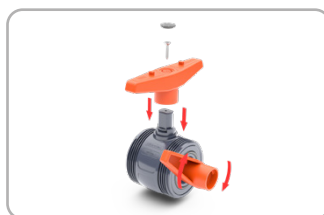

3. Una vez ajustado el portateflón volvemos a colocar la maneta. / Once the closing carrier is adjusted, the handle is placed again.

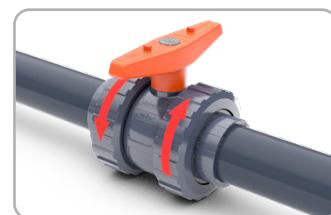

4. Volvemos a colocar la válvula apretando las tuercas, y el sistema puede trabajar con normalidad. / Fit the valve again, tightening the nuts and keep working normally.

VÁLVULA DE BOLA "BASIC" BIDIRECCIONAL / BIDIRECTIONAL "BASIC" BALL VALVE

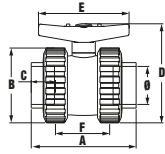

Salida encolar
Solvent socket outlet
Sortie à coller

643/648  

CÓDIGO / CODE	CÓDIGO / CODE	Ø TUBO / PIPE	DN	PESO / WT (g)	A	B	C	D	E	F
11D150	11D474	20	15	162	84	52	16	74	80	47
11D151	11D475	25	20	210	96	59	19	80	80	51
11D152	11D476	32	25	389	117	70	23	103	101	66
11D153	11D477	40	32	597	132	84	25	125	130	72
11D154	11D478	50	40	847	149	99	31	138	130	77
11D155	11D479	63	50	1.382	173	121	38	177	170	90
11D156	11D480	75	65	2.721	215	151	45	215	260	121
11D157	11D481	90	80	4.184	255	175	51	252	260	141





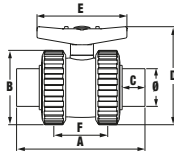

Salida encolar macho
Male solvent socket outlet
Sortie male à coller

785/788  

CÓDIGO / CODE	CÓDIGO / CODE	Ø TUBO / PIPE	DN	PESO / WT (g)	A	B	C	D	E	F
11D120	11D250	20	15	169	104	52	16	74	80	47
11D121	11D251	25	20	215	112	59	19	80	80	51
11D122	11D252	32	25	363	142	70	23	103	101	66
11D123	11D253	40	32	590	165	84	25	125	130	72
11D124	11D254	50	40	885	180	99	31	138	130	77
11D125	11D255	63	50	1.498	210	121	38	177	170	90





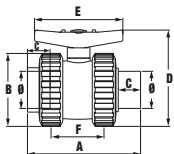

Salida encolar macho/encolar hembra
Male solvent socket/female solvent socket outlet
Sortie male-femelle à coller

786/789  

CÓDIGO / CODE	CÓDIGO / CODE	Ø TUBO / PIPE	DN	PESO / WT (g)	A	B	C	D	E	F
11D110	11D260	20	15	165	95	52	16	74	80	47
11D111	11D261	25	20	210	99	59	19	80	80	51
11D112	11D262	32	25	353	130	70	23	103	101	66
11D113	11D263	40	32	606	148	84	25	125	130	72
11D114	11D264	50	40	865	165	99	31	138	130	77
11D115	11D265	63	50	1.444	191	121	38	177	170	90

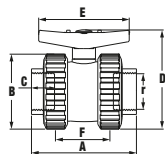

Salida R/Hembra
Female threaded outlet
Sortie taraudé

646/651  

CÓDIGO / CODE	CÓDIGO / CODE	r	DN	PESO / WT (g)	A	B	C	D	E	F
11D140	11D492	1/2"	15	170	91	52	17	74	80	47
11D141	11D493	3/4"	20	190	101	59	20	80	80	51
11D142	11D494	1"	25	362	120	70	23	103	101	66
11D143	11D495	1 1/4"	32	606	134	84	26	125	130	72
11D144	11D496	1 1/2"	40	856	153	99	33	138	130	77
11D145	11D497	2"	50	1.474	161	121	29	177	170	90
11D146	11D498	2 1/2"	65	2.500	204	151	33	215	260	121
11D147	11D499	3"	80	4.360	234	175	36	252	260	141

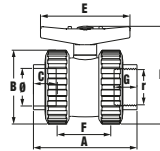

Salida mixta encolar R/H
Solvent socket/female threaded outlet
Sortie mixte

644/649



CÓDIGO / CODE	CÓDIGO / CODE	Ø - r	DN	PESO / WT (g)	A	B	C	D	E	F	G
11D160	11D483	20-1/2"	15	165	89	52	16	74	80	47	17
11D161	11D484	25-3/4"	20	210	99	59	19	80	80	51	20
11D162	11D485	32-1"	25	360	119	70	23	103	101	66	23
11D163	11D486	40-1 1/4"	32	600	133	84	25	125	130	72	26
11D164	11D487	50-1 1/2"	40	870	151	99	31	138	130	77	33
11D165	11D488	63-2"	50	1.410	167	121	38	177	170	90	29
11D166	11D489	75-2 1/2"	65	2.680	210	151	45	215	260	121	33
11D167	11D490	90-3"	80	4.290	245	175	51	252	260	141	36

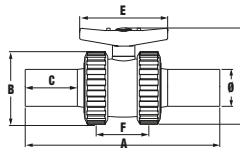

Salida termofusión
Thermofusion outlet
Sortie thermofusion

686/687



CÓDIGO / CODE	CÓDIGO / CODE	Ø TUBO / PIPE	DN	PESO / WT (g)	A	B	C	D	E	F
11D130	11D240	20	15	170	215	52	65	74	80	47
11D131	11D241	25	20	194	222	59	62	80	80	51
11D132	11D242	32	25	364	221	70	45	103	101	66
11D133	11D243	40	32	605	260	84	63	125	130	72
11D134	11D244	50	40	875	287	99	79	138	130	77
11D135	11D245	63	50	1.460	328	121	89	177	170	90
11D136	11D246	75	65	2.650	366	151	95	215	260	121
11D137	11D247	90	80	4.230	397	175	97	252	260	141

ACTUADOR ELÉCTRICO/ ELECTRIC ACTUATOR

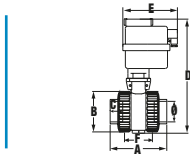

Salida encolar
Solvent socket outlet
Sortie à coller

653/668



CÓDIGO / CODE	CÓDIGO / CODE	Ø TUBO / PIPE	MOTOR	DN	PESO / WT (g)	A	B	C	D	E	F
11D299	11D349	20	H10	15	959	84	52	16	227	170	47
11D300	11D350	25	H10	20	1.006	96	59	19	232	170	51
11D301	11D351	32	H10	25	1.185	117	70	23	243	170	66
11D302	11D352	40	S20	32	2.590	132	84	25	265	170	72
11D303	11D353	50	S20	40	2.956	149	99	31	282	170	77
11D304	11D354	63	S20	50	3.822	173	121	38	352	170	90
11D305	11D355	75	S35	65	4.550	215	151	45	426	170	121
11D306	11D356	90	S55	80	6.630	255	175	51	453	170	141

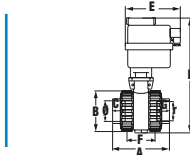

Salida mixta encolar R/H
Solvent socket/female threaded outlet
Sortie mixte

654/669



CÓDIGO / CODE	CÓDIGO / CODE	Ø TUBO / PIPE	MOTOR	DN	PESO / WT (g)	A	B	C	D	E	F	G
11D329	11D379	20-1/2"	H10	15	1.216	89	52	16	227	170	47	17
11D330	11D380	25-3/4"	H10	20	1.272	99	59	19	232	170	51	20
11D331	11D381	32-1"	H10	25	1.445	119	70	23	243	170	66	23
11D332	11D382	40-1 1/4"	S20	32	2.600	133	84	25	265	170	72	26
11D333	11D383	50-1 1/2"	S20	40	2.975	151	99	31	282	170	77	33
11D334	11D384	63-2"	S20	50	3.522	167	121	38	352	170	90	29
11D335	11D385	75-2 1/2"	S35	65	4.693	210	151	45	426	170	121	33
11D336	11D386	90-3"	S55	80	6.310	245	175	51	453	170	141	36

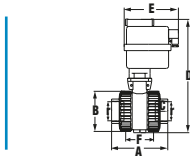

Salida R/Hembra
Female threaded outlet
Sortie taraudé

656/671



CÓDIGO / CODE	CÓDIGO / CODE	r	MOTOR	DN	PESO / WT (g)	A	B	C	D	E	F
11D309	11D359	1/2"	H10	15	1.216	91	52	17	227	170	47
11D310	11D360	3/4"	H10	20	1.276	101	59	20	232	170	51
11D311	11D361	1"	H10	25	1.450	120	70	23	243	170	66
11D312	11D362	1 1/4"	S20	32	2.609	134	84	26	265	170	72
11D313	11D363	1 1/2"	S20	40	2.986	153	99	33	282	170	77
11D314	11D364	2"	S20	50	4.018	161	121	29	352	170	90
11D315	11D365	2 1/2"	S35	65	4.610	204	151	33	426	170	121
11D316	11D366	3"	S55	80	6.760	234	175	36	453	170	141

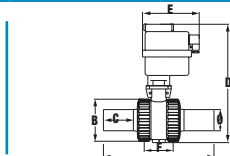

Salida termofusión
Thermofusion outlet
Sortie thermofusion

688/691



CÓDIGO / CODE	CÓDIGO / CODE	Ø TUBO / PIPE	MOTOR	DN	PESO / WT (g)	A	B	C	D	E	F
11D400	11D410	20	H10	15	1.220	215	52	65	227	170	47
11D401	11D411	25	H10	20	1.268	222	59	62	232	170	51
11D402	11D412	32	H10	25	1.456	221	70	45	243	170	66
11D403	11D413	40	S20	32	2.616	260	84	63	265	170	72
11D404	11D414	50	S20	40	2.956	287	99	79	282	170	77
11D405	11D415	63	S20	50	3.502	328	121	89	352	170	90
11D406	11D416	75	S35	65	4.550	366	151	95	426	170	121
11D407	11D417	90	S55	80	6.630	397	175	97	453	170	141

ACTUADOR NEUMÁTICO SIMPLE EFECTO / PNEUMATIC ACTUATOR SINGLE ACTING

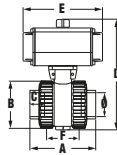

658/673

PTFE

VITON

Salida encolar
Solvent socket outlet
Sortie à coller

CÓDIGO / CODE	CÓDIGO / CODE	Ø TUBO / PIPE	MOTOR	DN	PESO / WT (g)	A	B	C	D	E	F
11D500	11D550	20	H050SE	15	1.690	84	52	16	211	138	47
11D501	11D551	25	H050SE	20	1.215	96	59	19	219	138	51
11D502	11D552	32	H050SE	25	1.888	117	70	23	230	138	66
11D503	11D553	40	H063SE	32	2.690	132	84	25	249	155	72
11D504	11D554	50	H063SE	40	3.056	149	99	31	267	155	77
11D505	11D555	63	H063SE	50	3.572	173	121	38	352	155	90
11D506	11D556	75	H075SE	65	5.570	215	151	45	426	210	121
11D507	11D557	90	H100SE	80	11.430	255	175	51	450	280	141

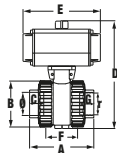

659/674

PTFE

VITON

Salida mixta encolar R/H
Solvent socket/female threaded outlet
Sortie mixte

CÓDIGO / CODE	CÓDIGO / CODE	Ø - r	MOTOR	DN	PESO / WT (g)	A	B	C	D	E	F	G
11D530	11D580	20-1/2"	H050SE	15	1.612	89	52	16	211	138	47	17
11D531	11D581	25-3/4"	H050SE	20	1.672	99	59	19	219	138	51	20
11D532	11D582	32-1"	H050SE	25	1.845	119	70	23	230	138	66	23
11D533	11D583	40-1 1/4"	H063SE	32	2.699	133	84	25	249	155	72	26
11D534	11D584	50-1 1/2"	H063SE	40	3.075	151	99	31	267	155	77	33
11D535	11D585	63-2"	H063SE	50	3.622	167	121	38	352	155	90	29
11D536	11D586	75-2 1/2"	H075SE	65	5.678	210	151	45	426	210	121	33
11D537	11D587	90-3"	H100SE	80	11.540	245	175	51	450	280	141	36

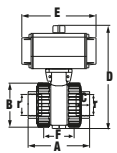

661/676

PTFE

VITON

Salida R/Hembra
Female threaded outlet
Sortie taraudé

CÓDIGO / CODE	CÓDIGO / CODE	r	MOTOR	DN	PESO / WT (g)	A	B	C	D	E	F
11D510	11D560	1/2"	H050SE	15	1.616	91	52	17	211	138	47
11D511	11D561	3/4"	H050SE	20	1.676	101	59	20	219	138	51
11D512	11D562	1"	H050SE	25	1.850	120	70	23	230	138	66
11D513	11D563	1 1/4"	H063SE	32	2.814	134	84	26	249	155	72
11D514	11D564	1 1/2"	H063SE	40	3.086	153	99	33	267	155	77
11D515	11D565	2"	H063SE	50	3.672	161	121	29	352	155	90
11D516	11D566	2 1/2"	H075SE	65	5.711	204	151	33	426	210	121
11D517	11D567	3"	H100SE	80	11.610	234	175	36	450	280	141

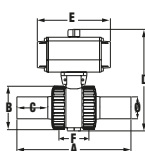
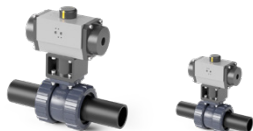

689/692

PTFE

VITON

Salida termofusión
Thermofusion outlet
Sortie thermofusion

CÓDIGO / CODE	CÓDIGO / CODE	Ø TUBO / PIPE	MOTOR	DN	PESO / WT (g)	A	B	C	D	E	F
11D700	11D720	20	H050SE	15	1.620	215	52	65	211	138	47
11D701	11D721	25	H050SE	20	1.668	222	59	62	219	138	51
11D702	11D722	32	H050SE	25	1.855	221	70	45	230	138	66
11D703	11D723	40	H063SE	32	2.716	260	84	63	249	155	72
11D704	11D724	50	H063SE	40	3.056	287	99	79	267	155	77
11D705	11D725	63	H063SE	50	3.602	328	121	89	352	155	90
11D706	11D726	75	H075SE	65	5.568	366	151	95	426	210	121
11D707	11D727	90	H100SE	80	11.430	397	175	97	450	280	141

ACTUADOR NEUMÁTICO DOBLE EFECTO / PNEUMATIC ACTUATOR DOUBLE ACTING

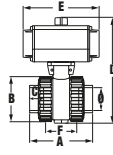

Salida encolar
Solvent socket outlet
Sortie à coller

663/678

CÓDIGO / CODE	CÓDIGO / CODE	Ø TUBO / PIPE	MOTOR	DN	PESO / WT (g)	A	B	C	D	E	F
11D600	11D650	20	H050DE	15	862	84	52	16	211	138	47
11D601	11D651	25	H050DE	20	918	96	59	19	219	138	51
11D602	11D652	32	H050DE	25	1.840	117	70	23	230	138	66
11D603	11D653	40	H050DE	32	2.090	132	84	25	249	155	72
11D604	11D654	50	H050DE	40	2.433	149	99	31	267	155	77
11D605	11D655	63	H050DE	50	3.077	173	121	38	352	155	90
11D606	11D656	75	H075DE	65	6.010	215	151	45	426	210	121
11D607	11D657	90	H075DE	80	7.590	255	175	51	450	280	141

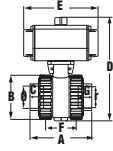
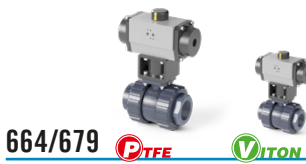

Salida mixta encolar R/H
Solvent socket/female threaded outlet
Sortie mixte

664/679

CÓDIGO / CODE	CÓDIGO / CODE	Ø - r	MOTOR	DN	PESO / WT (g)	A	B	C	D	E	F	G
11D630	11D680	20-1/2"	H050DE	15	862	89	52	16	211	138	47	17
11D631	11D681	25-3/4"	H050DE	20	922	99	59	19	219	138	51	20
11D632	11D682	32-1"	H050DE	25	1.845	119	70	23	230	138	66	23
11D633	11D683	40-1 1/4"	H050DE	32	2.099	133	84	25	249	155	72	26
11D634	11D684	50-1 1/2"	H050DE	40	2.475	151	99	31	267	155	77	33
11D635	11D685	63-2"	H050DE	50	3.022	167	121	38	352	155	90	29
11D636	11D686	75-2 1/2"	H075DE	65	6.121	210	151	45	426	210	121	33
11D637	11D687	90-3"	H075DE	80	7.190	245	175	51	450	280	141	36

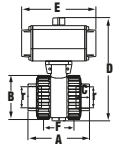

Salida R/Hembra
Female threaded outlet
Sortie taraudé

666/681

CÓDIGO / CODE	CÓDIGO / CODE	r	MOTOR	DN	PESO / WT (g)	A	B	C	D	E	F
11D610	11D660	1/2"	H050DE	15	866	91	52	17	211	138	47
11D611	11D661	3/4"	H050DE	20	926	101	59	20	219	138	51
11D612	11D662	1"	H050DE	25	1.850	120	70	23	230	138	66
11D613	11D663	1 1/4"	H050DE	32	2.110	134	84	26	249	155	72
11D614	11D664	1 1/2"	H050DE	40	2.486	153	99	33	267	155	77
11D615	11D665	2"	H050DE	50	3.072	161	121	29	352	155	90
11D616	11D666	2 1/2"	H075DE	65	6.154	204	151	33	426	210	121
11D617	11D667	3"	H075DE	80	7.260	234	175	36	450	280	141

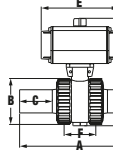

Salida termofusión
Thermofusion outlet
Sortie thermofusion

690/693

CÓDIGO / CODE	CÓDIGO / CODE	Ø TUBO / PIPE	MOTOR	DN	PESO / WT (g)	A	B	C	D	E	F
11D710	11D730	20	H050DE	15	870	215	52	65	211	138	47
11D711	11D731	25	H050DE	20	918	222	59	62	219	138	51
11D712	11D732	32	H050DE	25	1.856	221	70	45	230	138	66
11D713	11D733	40	H050DE	32	2.116	260	84	63	249	155	72
11D714	11D734	50	H050DE	40	2.455	287	99	79	267	155	77
11D715	11D735	63	H050DE	50	3.002	328	121	89	352	155	90
11D716	11D736	75	H075DE	65	6.011	366	151	95	426	210	121
11D717	11D737	90	H075DE	80	7.591	397	175	97	450	280	141

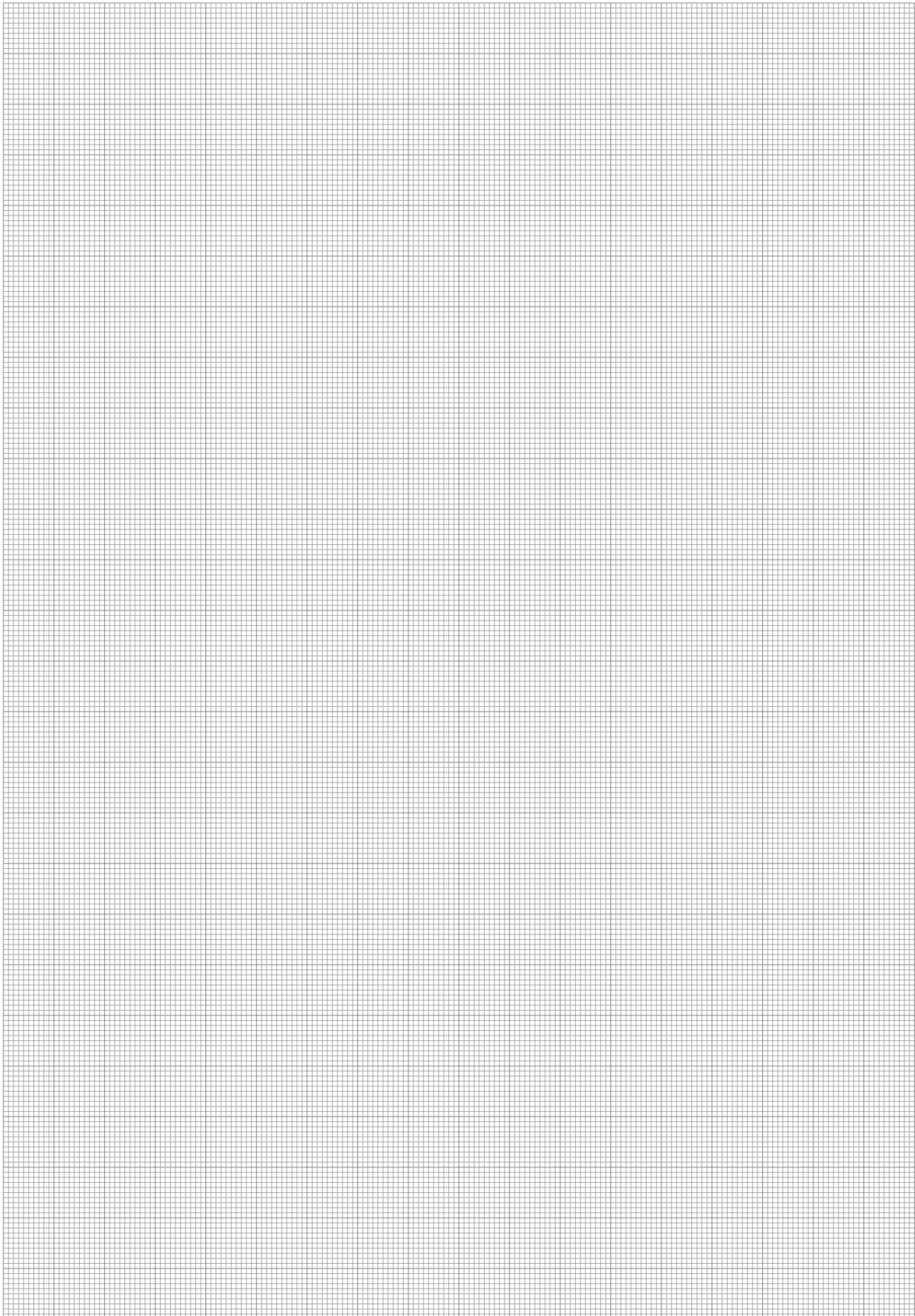

HIDROTEN, S.A.

Pol. Ind. Plá Vallonga, c/ Agua, 28
03006 ALICANTE (España)
Tel. 965 11 42 82
Fax: 965 11 48 62

I INTERNACIONALES I

Tel. +34 965 11 42 82
Fax: +34 965 11 48 62
Tel. Información Técnica:
+34 966 105 888

www.hidroten.es

I E-mails I

comercial@hidroten.es
export@hidroten.es
administracion@hidroten.es
tecnico@hidroten.es
publicidad@hidroten.es
prescripcion@hidroten.es



¡Síguenos en redes sociales!

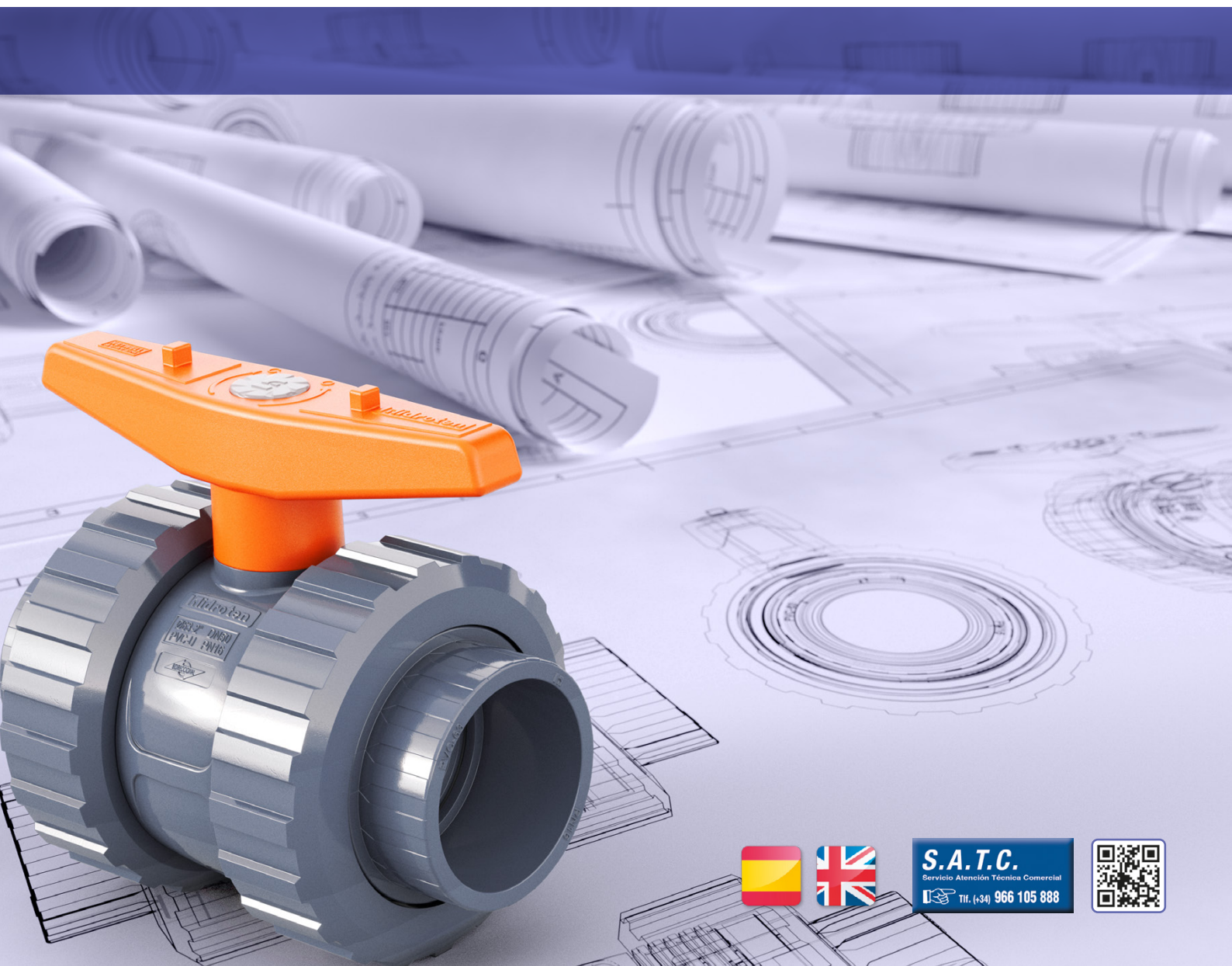

S.A.T.C.
Servicio Atención Técnica Comercial
Tlf. (+34) 966 105 888

